

## ENERGY SYSTEMS

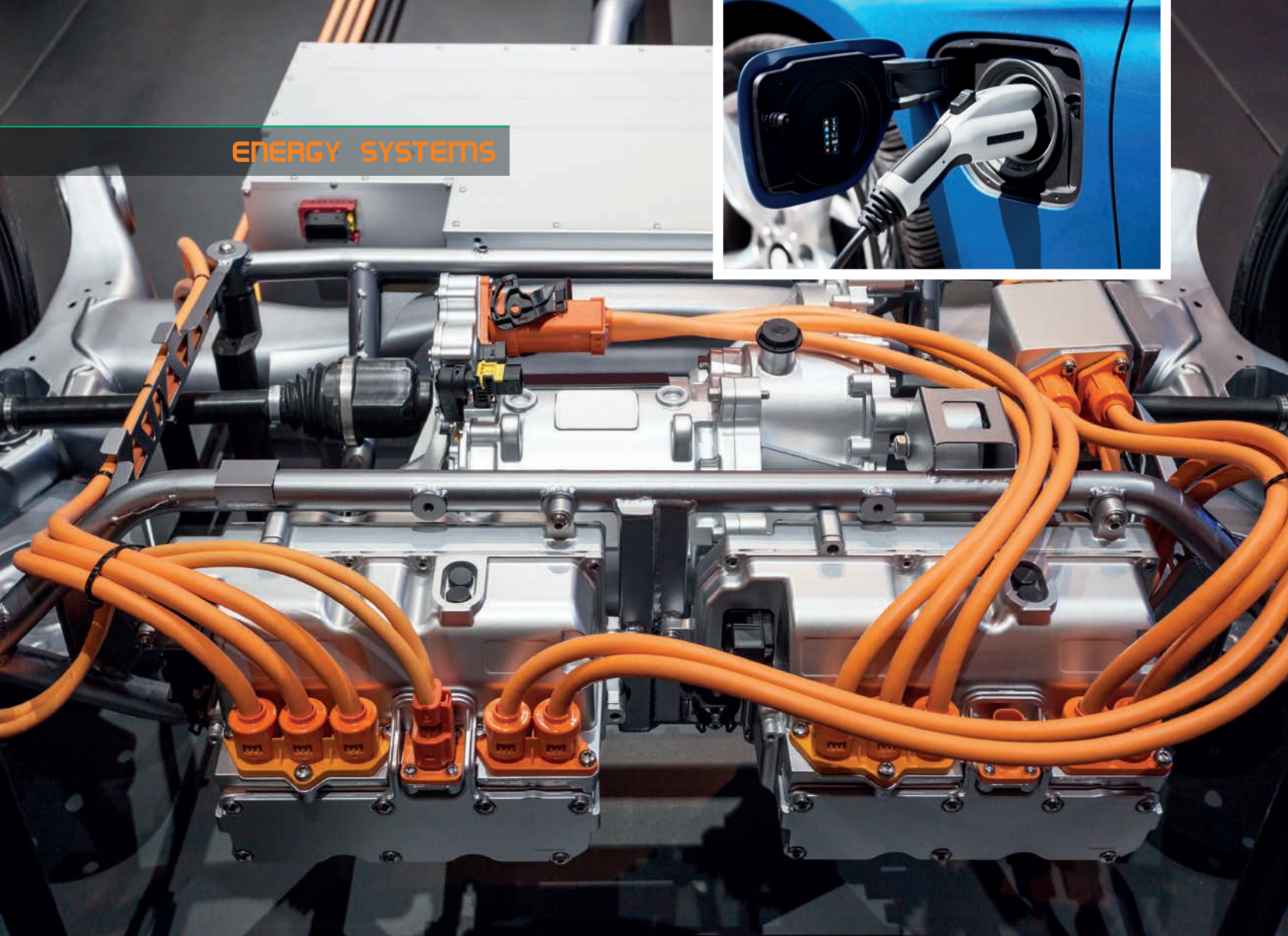

■ Mark-M. Bakran  
Michael Gleißner  
Teresa Bertelshofer

# Batteries and electric drives

System considerations for e-mobility

■ *Transmission of a plug-in hybrid vehicle (sst).*  
Small photo: *Charging of a plug-in hybrid vehicle (sst).*

For most people, the battery probably comes to mind as the most critical aspect of e-mobility. The battery determines the range, and to a large extent, the additional costs and the additional weight compared to an internal combustion vehicle. From the point of view of the vehicle's drive, however, the battery is only one of many components in the electric drive train. Taken as a system component, the battery has to contend with a completely different set of demands than, for example, those seen from the electrochemistry perspective.

The task of vehicle system design is to consider all the conceivable system states of a vehicle, operating in different driving cycles, under different conditions within temperature ranges or loading regimes, for example, and to calculate the electrical and thermal behaviour in each case. On top of all that, an accurate prediction of the expected service life is required, too. The challenge here is that modelling must be carried out through several orders of magnitude in the time scale. The characterization of a battery cell is usually in terms of electrical frequency. System design, on the other hand, depends on a model that can be applied in terms of time. Moreover, this modelling must consider the electrical and thermal behaviour as interconnected.

The Chair of Mechatronics, a member of the Centre for Energy Technology (ZET) at the University of Bayreuth, looks at the battery from the perspective of power electronics. This is the intermediary between battery and drive motor for every electrically driven vehicle. This is where the adjustable voltages for the speed control of the machine are generated, but also the pulsed current, which loads the battery. Power electronics are thus decisive for battery load, for example, when providing high-frequency current; but

at the same time, the voltage response of the battery is decisive for drive design, as well as for the torque that can be achieved, and the speed of the traction motor.

This special view of the battery leads to the insight that power electronics must use adapted electrical and thermal models of the battery, which can remain applicable to the special load profiles.

### Electric drive train in a vehicle

Purely electric vehicles (Battery Electric Vehicles, BEV) are operated solely with a battery. Hybrid vehicles (HEVs), on the other hand, have at least one other drive in addition to an electric motor. Whether a vehicle is designed as a mild, full or plug-in hybrid, or is indeed a purely electric vehicle, essentially determines the performance class of the electric drive, and also the energy of the battery to be installed, but invariably leads to a near identical electric drive structure (Fig. 2). And should the fuel cell one day be of interest as a supplier of energy, the electric drive structure will still look like that of a serial hybrid vehicle today.



Fig. 1: Dipl.-Ing. Teresa Bertelshofer and Dr.-Ing. Michael Gleißner measuring an inverter in the test hall of the Chair of Mechatronics (Photo: Christian Wiffler).

**„Since the battery is the most expensive individual component in a battery-powered vehicle, measures to increase efficiency are highly worthwhile.“**

The available electrical voltage at the battery terminals is both a key factor and a problem, because the driver demands full performance even in cold and

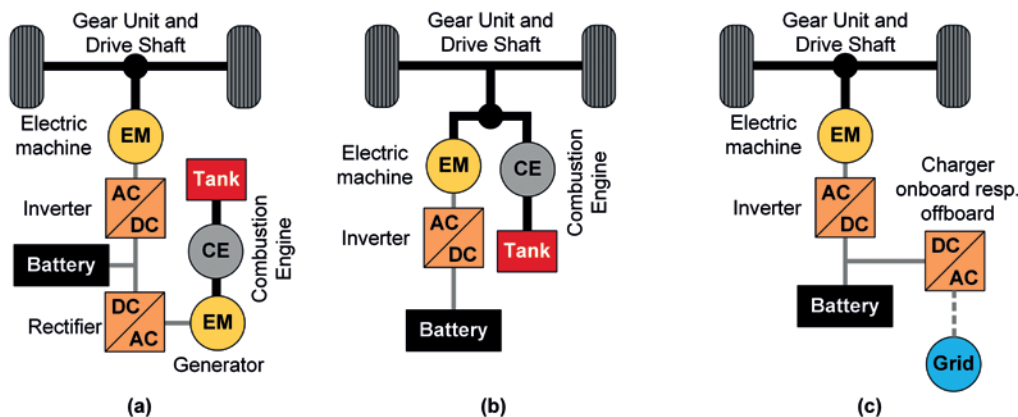
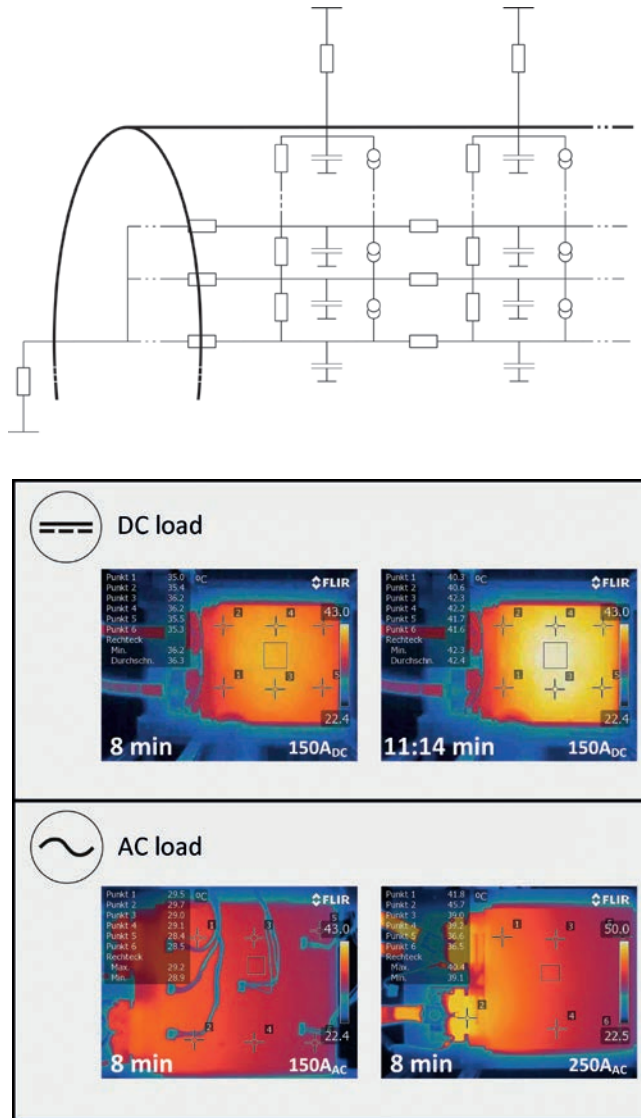

Fig. 2: Electric drive structure of a) Serial Hybrid Electric Vehicle, b) Parallel Hybrid Electric Vehicle, c) Battery Electric Vehicle (Illustration: Mark-M. Bakran / Michael Gleißner).

■ Fig. 3: Thermal system modeling: a) Representative thermal model of a battery system, b) Measurements on a battery with AC and DC load (Illustrations and images: Mark-M. Bakran / Michael Gleißner).



in the engineering sector, system optimization with many influencing variables and, at the end of the day, the goal of realizing a function as cost-effectively as possible. For instance, you have to answer the question: Should a cold battery be warmed for better performance, and – if so – should this be done externally or by actively loading the battery? A similar question applies to the other case, namely for the battery that is too warm: Should cooling be improved here, or the load reduced (Fig. 3)? And in each case it is important to consider what will be acceptable for the driver, and what they would see as a severe limitation. For example, they might feel restricted in their accustomed driving style if the vehicle did not accelerate as expected.

In fact, the real driving profile of an electric car differs significantly from the load on the battery, which is typically used by the cell manufacturer for characterization purposes. We encounter processes changing rapidly over time – Fig. 4 shows typical electrical influencing variables. It is clearly visible that the current load of the battery can be highly uneven. On the other hand, it can also be seen that the available drive torque is strongly influenced by the battery. This torque characteristic is at the same time the great strength of the electric car, because the full torque is constant and immediately available before maximum power is reached. This results in the impressive performance we see when an electric car leaves most more powerful vehicles with internal combustion engines standing at the traffic lights.

low batteries. System design therefore has to solve the problem that, on the one hand, maximum battery voltage represents the highest electrical load for the power electronics, while on the other, minimum battery voltage determines the performance that can be achieved. This brings us to a typical problem

### Optimization of power electronics for battery electric vehicles

Another fundamental topic of system design that includes the battery is efficiency. Even if the efficiency of an electric drive train is very high, losses naturally still occur. Here it is striking that the further

■ Fig. 4: Influencing factors on battery design in electric vehicles. Current load in operational cycle (left), speed-torque characteristic curve of the driving motor (right) (Illustrations: Mark-M. Bakran / Michael Gleißner).

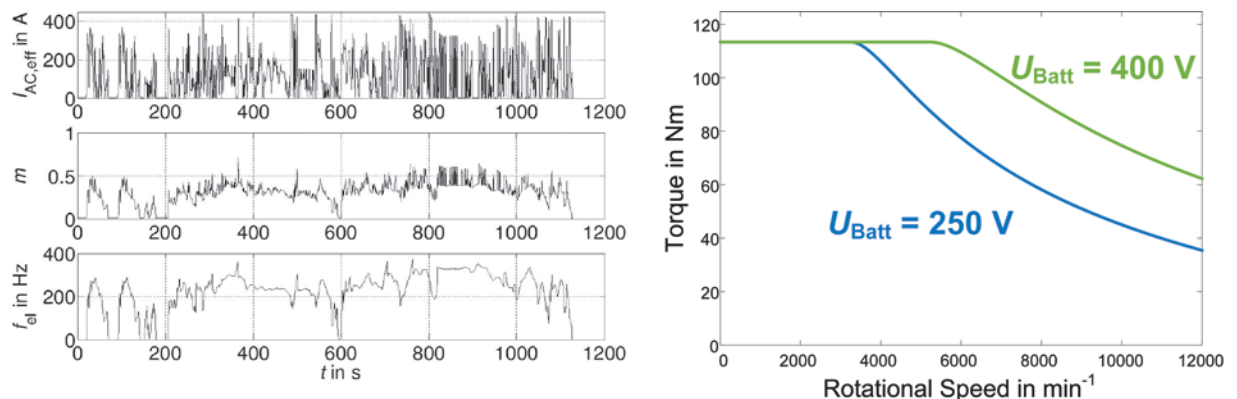

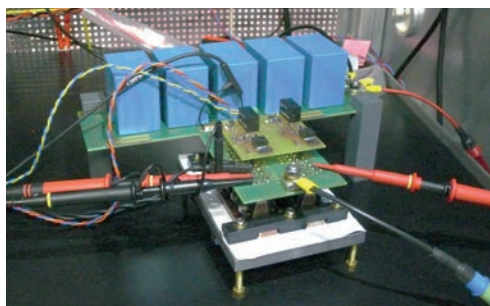
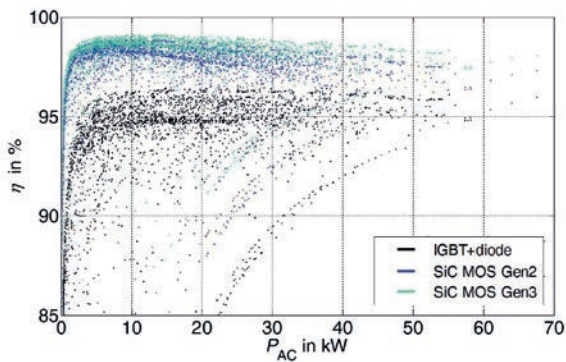

■ Fig. 5: Efficiency comparison of a conventional inverter and a silicon carbide inverter (left), characterization measuring station for a SiC semiconductor (right) (Illustration and photo: Mark-M. Bakran / Michael Gleißner).

back in the drive train the losses occur, i.e. towards the drive motor, the more expensive they become. This is because the system components in front of each other have to provide additional power, which in turn results in losses. Since the battery is the most expensive individual component in a BEV, measures to increase efficiency are extremely worthwhile in this regard: for example, a three percent increase in efficiency in the drive reduces the cost of the battery by exactly three percent. The main focus of research in this area is currently on the use of new semiconductors in power electronics.

chatronics at the University of Bayreuth is investigating such components, and is developing complete inverters for the drive. Here, real driving profiles can be used to demonstrate the extent of efficiency improvements (Fig. 5).

### Fast charging of batteries in electric vehicles

Discussions about shorter charging times for electric cars are also a growing issue in the media. In this regard, charging capacities of well above 150 kilowatts are routinely bandied about. Even for the charging capacity of around 100 kilowatts that can be achieved today, the battery is already the limiting element in the system. For this reason, charging power must be greatly reduced at higher charge levels in order not to damage the battery.

For even greater performance, the additional challenge is that this can only be achieved at higher voltages. This means that the voltage must be increased from around 400 volts DC, as is typical these days, to 800 volts, in order to be able to carry the necessary current via the charging cable. Where a battery system today already requires a series connection of about 100 individual cells, this will then increase to 200. This will also increase the effort required to balance the charge differences in the individual battery cells, the cell symmetry, because every battery cell naturally has production-related tolerances. If the weakest cell is not to limit the overall performance, then balancing must be carried out with the aid of power electronics (Fig. 7a).

Here, too, the interplay of battery and system must be characterized very precisely, because too much balancing power increases the overall costs and reduces efficiency. On the other hand, the specping of excessive levels of manufacturing quality increases

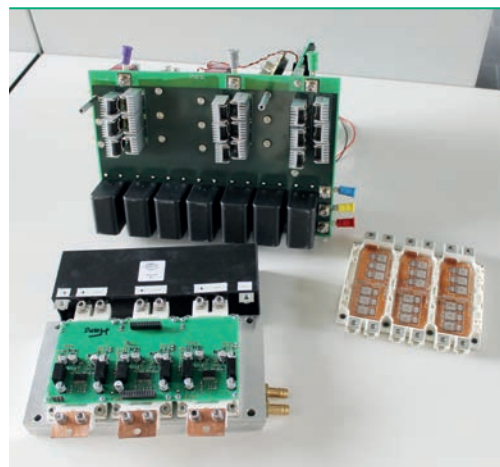

■ Fig. 6: Small inverter for use in battery research (Photo: Christian Wiffler).

Here, the so-called wide-bandgap material silicon carbide promises significant advantages. „Wide-bandgap“ refers to a larger band gap compared to normal silicon. This increases the load capacity of the component with voltage, which is why the components only have to be 1/10 as thick. These thinner components in turn enable a significant reduction in losses during power supply. The Department of Me-

### AUTHORS



■ Prof. Dr.-Ing. Mark-M. Bakran is Chair of Mechatronics at the University of Bayreuth.



■ Dr.-Ing. Michael Gleißner is a research associate at the Chair of Mechatronics.



■ Dipl.-Ing. Teresa Bertelshofer is a research associate at the Chair of Mechatronics.

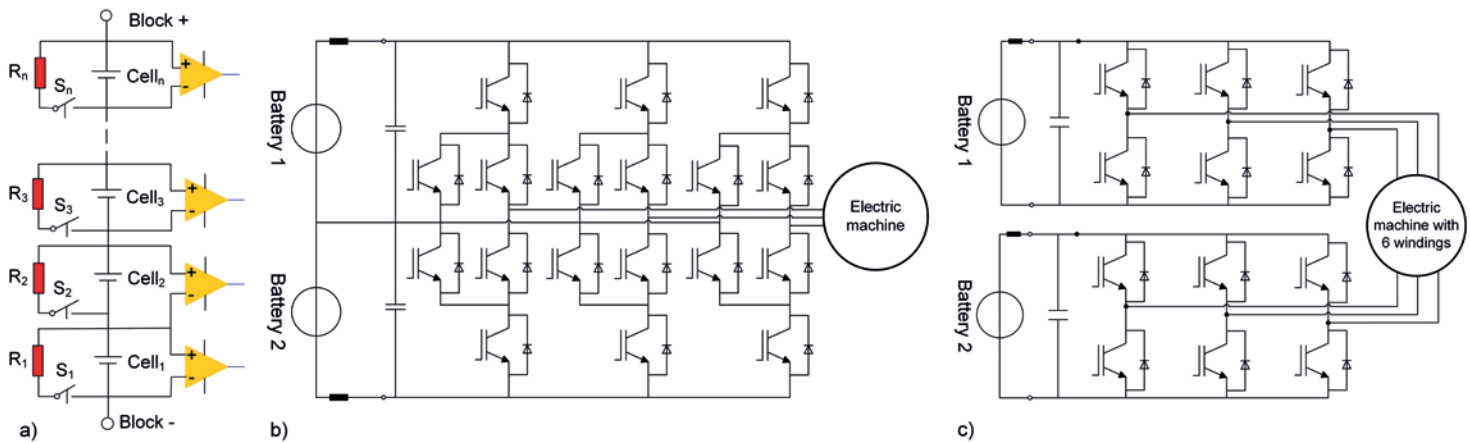

■ Fig. 7: Diagram of the cell series circuit with balancing via resistors (a); diagram of a split battery with multi-level inverter (b) and with multi-phase motor (c) (Illustrations: Mark-M. Bakran / Michael Gleißner).

the costs per cell. Again, an evaluation is only possible from a system perspective, by means of which it is possible to determine, for a given manufacturing tolerance, the exact balancing performance to be maintained. Also from the system perspective, this procedure must be compared with alternative approaches. In this case, for example, this would be the division of the complete battery into two partial batteries.

Such an approach is again only possible if the structure of the drive system is adapted accordingly. Again, there are two exemplary approaches:

- Either one uses adapted power electronics that are capable of feeding a motor from two partial batteries (Fig. 7b),
- or using a special electrical version of the motor that uses several winding systems (Fig. 7c).

In the first case, so-called 3-level or multi-level inverters are used, which offer additional potential for increasing efficiency. In the second case, a drive concept is achieved which is capable of maintaining driving operation even after a fault in a subsystem.

### Summary

This exemplary presentation of topics relating to the electric drive system of a vehicle has shown that there is no component that does not have repercussions on the entire drive system, and that there is hardly a system decision that does not have a repercussion on the battery as a system component. An understanding of the battery from the system perspective is therefore the key to achieving the overall optimum. And everyone who drives an electrically powered vehicle in the future will be thankful for this optimum in the end.

■ Fig. 8: The Chair of Mechatronics led by Prof. Dr.-Ing. Marc-M. Bakran gave support to the Elephant Racing team of Bayreuth University in 2019 again, in particular with regard to the construction of an electrically driven race car (Photo: © Elephant Racing).



■ Philipp Wetzlar and Felix Krohn

# Pole position thanks to electric drive technology



Elefant Racing e.V., a student initiative at the University of Bayreuth, already has quite a tradition: since 2004, the University has been taking part in an annual worldwide racing series – the „Formula Student“ – with racing cars built by its students. The team has often received international attention due to the success it has achieved in this area. There are currently almost 50 students from the fields of engineering, business administration, and computer science who are implementing their innovative technical ideas to compete against student teams from other universities in Germany and abroad.

In 2011, Elefant Racing was one of the first Formula Student teams to make the switch to electric drives. Since then, a new electric racing car has been built on Bayreuth's campus every year. This has enabled our students to gain a considerable advantage with regard to knowledge and experience. One example is the battery packaging concept, which radically changed in 2019 due to the introduction of an all-wheel drive system: the previous two-part lithium polymer batteries were replaced by one large battery in the vehicle fuselage. This transition to a new battery concept not only further reduces weight but

also increases safety. Furthermore, the cells were tested under racing conditions for the first time this year.

The race car from Bayreuth weighs only 200 kilograms and can accelerate from 0 to 100 km/h in just 2.5 seconds. It is able to reach a top speed of 125 km/h.

■ Fig. 1: The race car „FR 19 Loki“ of the Elefant Racing Team 2019 (Photo: © Elefant Racing).



■ Fig. 2: Installation of the battery in the race car (Photo: © Elefant Racing).

## FACT SHEET

- Cells are divided into 6 „cell packs“.
- 280 cells (pouch cells) 140S2P.
- 6.84 kilowatt hours.
- 420-588 volts.
- Discharge current >200 amps.
- Charging current ~100 amps.
- In the safety system, relays separate the positive pole from the negative pole of the battery. The status of the relays is monitored.
- Its own battery management system.
- IMD (insulation monitoring device) board for insulation monitoring between high and low voltage.
- The LV system is supplied via two isolated voltage transformers from the HV system.
- The battery is air-cooled by six integrated fans (~100W) and additionally secured by an automatic safety device which closes the additional ventilation slots in the battery box in the event of an error.

In 2019, the Elefant Racing team once again received support from renowned high-tech companies for both the construction and testing of its race car. And without the close cooperation with the Mechatronics Research Group under the direction of Prof. Dr. Mark.-M. Bakran, the switch to all-wheel drive would not have been possible. Two members of the Bayreuth team wrote their master's theses in engineering on the wheel hub motors they had developed themselves to help make the drive system a reality.

It does not make sense to transfer the concept of the new electric racing car developed in Bayreuth to everyday automobiles since the battery is designed for racing and therefore has a very low storage capacity. However, a look back at the enormous technical advances made since the first Formula Student 15 years ago gives cause for optimism. Electric mobility definitely has a future, and Elefant Racing will continue to advance this field with creative design ideas.

## AUTHORS

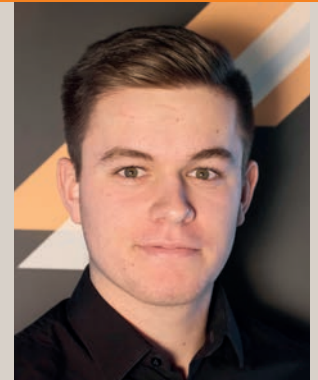

■ Felix Krohn, 1st Chairman of Elefant Racing e.V.

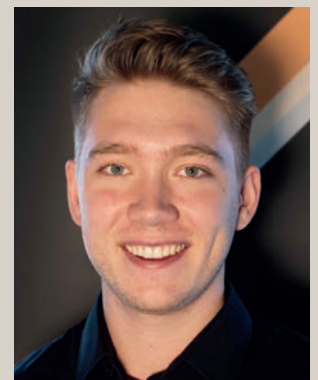

■ Philipp Wetzlar, 2nd Chairman of Elefant Racing e.V.